

M2D Bridge V1.0

Matter to DALI Bridge - Broadcast



Product description

- Matter to DALI Bridge
- Wireless controllable with Matter controller
- Connection over IPV6 WLAN network
- Integrated DALI power supply for max. 8 DALI-Drivers
- Broadcast Control of Standard and TW(DT8) DALI-Drivers
- ENEC, UL and Matter certified

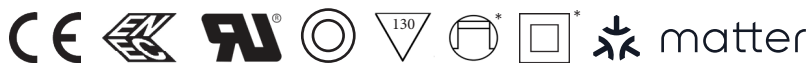

*details on page 8.

M2D Bridge VI.O

Matter to DALI Bridge - Broadcast



Technical data	
Rated supply voltage	110V - 240 V
Mains frequency	50/60 Hz
Max. power input	1.5 W
Connectivity standards	Matter
WLAN frequency	2.4 - 2.5 GHz
Max. output power (E.I.R.P.) 802.11 b WIFI 802.11 g/n WIFI	< +18.22 dBm < +19.99 dBm
Output	DALI (compatible)
Number of DALI addresses	Broadcast - no addressing
Guaranteed output current, DALI	16 mA - max. 8 loads
Max. output current, DALI	50 mA
Max. DALI wiring length	10 m at 1 mm ²
Ambient temperature t_a	-20 ... +60 °C
Max. casing temperature t_c	80 °C
Dimensions L x B x H	74 x 30 x 21 mm
Wire gauge	0.2 ... 1.5 mm / 24 ... 16 AWG
Lifetime	up to 50000 h
Article number	0001

M2D Bridge V1.0

Matter to DALI Bridge - Broadcast



Details

Dimensions [mm]

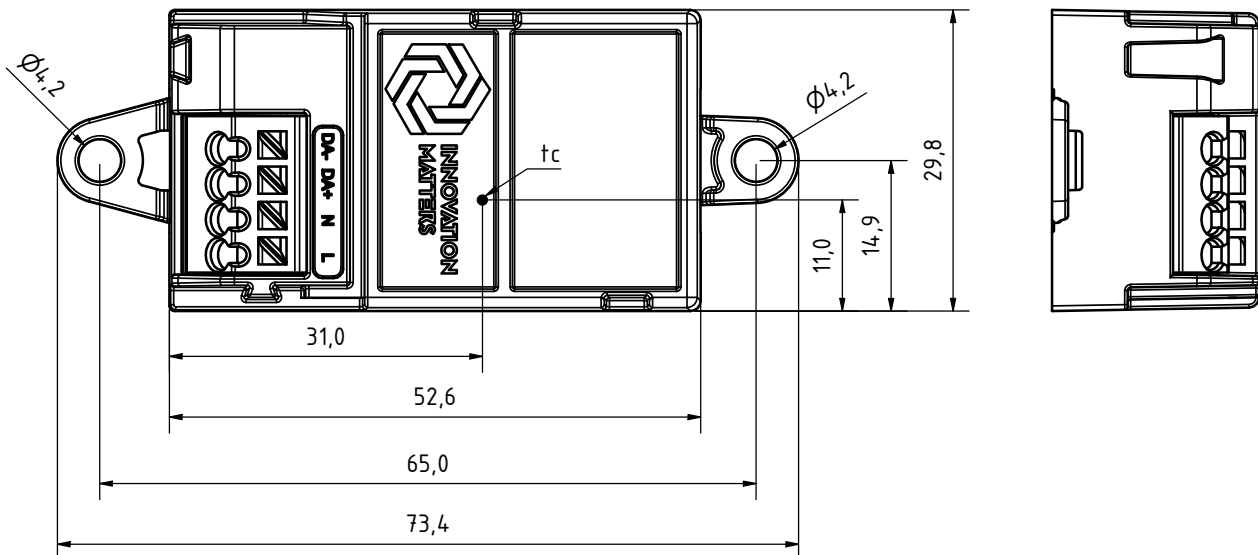
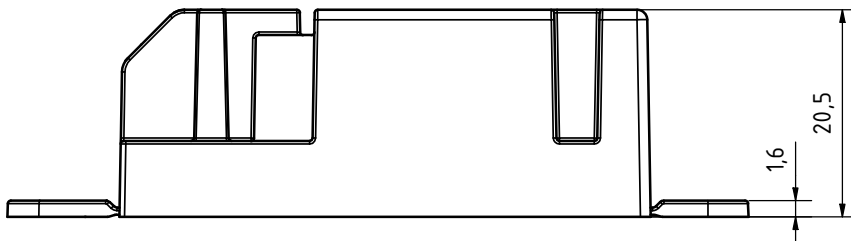

M2D Bridge V1.0

Matter to DALI Bridge - Broadcast



Description

The Matter to DALI (M2D) Bridge is an interface between the Matter and DALI standard. The bridge has an integrated DALI supply, which means that a separate supply is not needed. The output supplies a guaranteed output current for up to 8 DALI drivers.

In addition to standard LED drivers, Tunable White (TW) LED drivers can also be controlled.

Commissioning

A factory new Matter to DALI Bridge will let connected luminaires fade between on and off for the first 15 seconds after booting (a “breathing” effect). This indicates that the device is ready to be commissioned by a Matter controller.

Note: The device will stop advertising itself after 15 minutes without a connection attempt. Restart the device to be able to commission the device again for 15 minutes.

To commission the device with a Matter controller the QR-code, printed on the device and supplied in the packaging, must be scanned. Alternatively, it is possible to use a setup code also printed on the device.

Controllers provide means to either scan the QR-code or to enter the setup code.

After the commissioning process is finished, the device will appear in the user interface of the controller used to commission it and is ready to be controlled.

List of certified Matter controllers: [connectivity standards alliance](#)

Commissioning to another Matter controller

The Matter controller, used to first commission the device, can open a commissioning window on already commissioned devices. Use this functionality to put the device into pairing mode, a setup code will be displayed in the app used to perform these steps.

This setup code can be used to connect to the device from a second controller in the same way the setup code can be used to initially commission the device. Afterwards the device can be controlled from both connected controllers.

Note: The setup code displayed on the app used to first commission the device is different from the one printed on the device. To add the device to a second controller it is necessary to use the setup code displayed in the app.

Factory reset

To perform a factory reset of a commissioned Matter to DALI Bridge the user must power cycle the device (i.e., turn the device on and off) 11 times in a row. It is irrelevant how long the device is off, not supplied with power, however it is important to not let the device be on for less than 2 seconds and more than 10 seconds. If the device was on for more than 10 seconds during this process the factory reset is aborted and the 11 power cycles must be started from the beginning.

After that the device will fade the connected luminaires again between on and off for 15 seconds. The device will be on and dimmed to the maximum value afterwards. All settings will be lost, and the device is ready to be commissioned again.

Installation

Wiring diagram

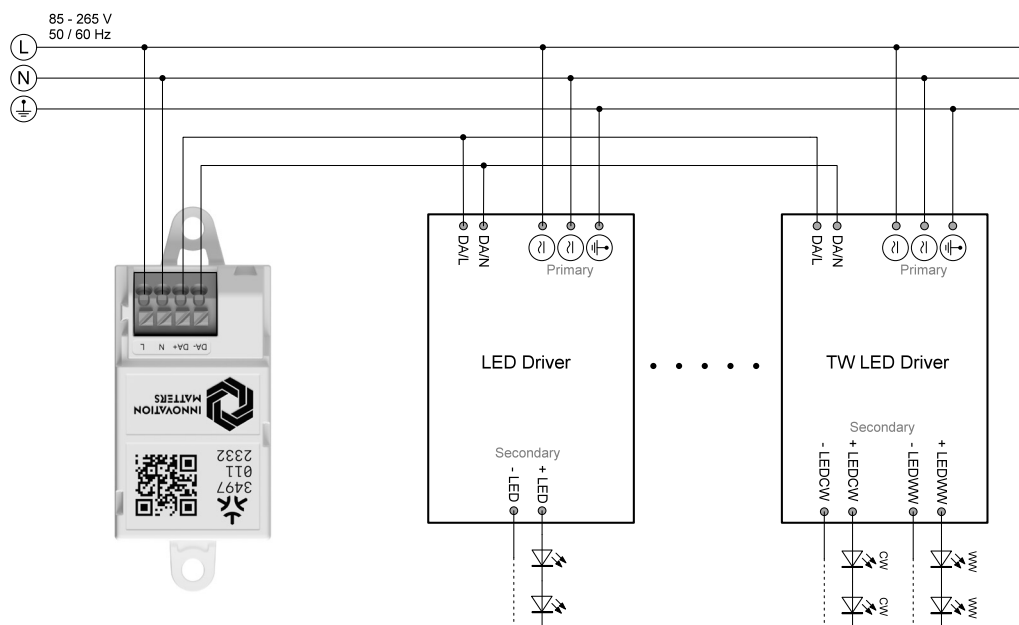

Cross section and wire types:

For the wiring between the M2D Bridge and the LED drivers, solid wires as well as stranded wires can be used.

The recommended cross-sections and dimensions of the stripping of the insulation are shown in the figure below. The suggested wire size is from min. 0.2 mm² to max. 1.5 mm² or 24AWG to 16AWG.

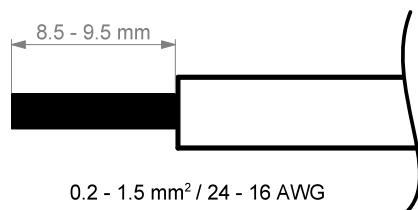

If the external flexible cable or cord of the luminaire/driver is damaged, it shall be exclusively replaced by the manufacturer or his service agent or a similar qualified person in order to avoid hazards.

M2D Bridge V1.0

Matter to DALI Bridge - Broadcast



Device placement

The M2D Bridge has an integrated WiFi antenna (2.4 GHz), with an omnidirectional radiation pattern. To achieve the best communication performance, there should be no metallic objects or surfaces in the immediate area of the antenna.

To improve the operating range, the marked area should ideally not be in contact with a metallic surface. In general, the M2D Bridge must not be installed in a fully closed metallic housing. The environmental parameters (e.g. building construction, obstacles such as furniture, ...) are important for the maximum operating range. The optimal alignment and position of the M2D Bridge should be tested during installation.

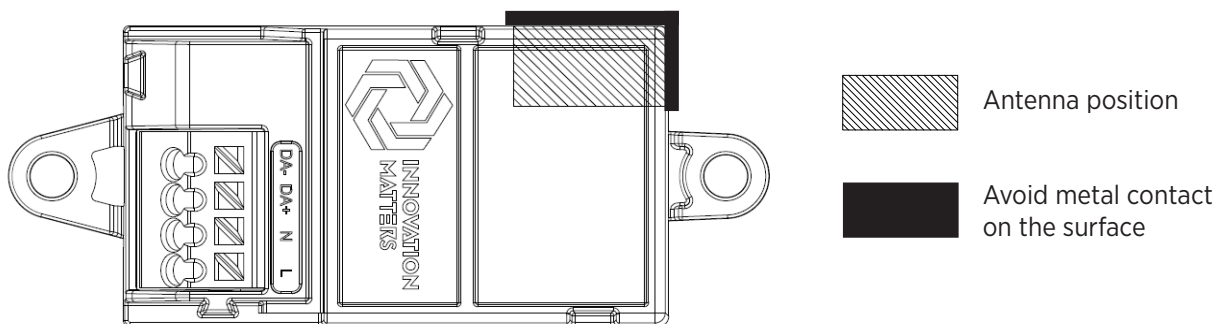

Mounting

Maximum tightening torque: 1 Nm

Standards

EN 61347-1

EN 61347-2-11

UL 8750, 2nd Edition

Certification marks

ENEC:

ENEC-04318

UL Recognized Component:

[E530583](#)

Matter:

[CSA22001MAT40001-24](#)

M2D Bridge V1.0

Matter to DALI Bridge - Broadcast



Insulation

Product provides BASIC insulation complying for 240 V between main supply circuit (LV) and output circuit (FELV).

Product provides DOUBLE insulation complying for 240 V between main supply circuit (LV) and external accessible conductive metal parts.

Product provides SUPPLEMENTARY insulation complying for 240 V between output circuit (FELV) and external accessible conductive metal parts.



The M2D Bridge, if used as a Build-In product, provides double insulation complying for 240V between mains supply circuit (LV) and external accessible metallic parts.

Thermal

The maximum allowed casing temperature t_c is 80°C at a maximum ambient temperature of 60°C.

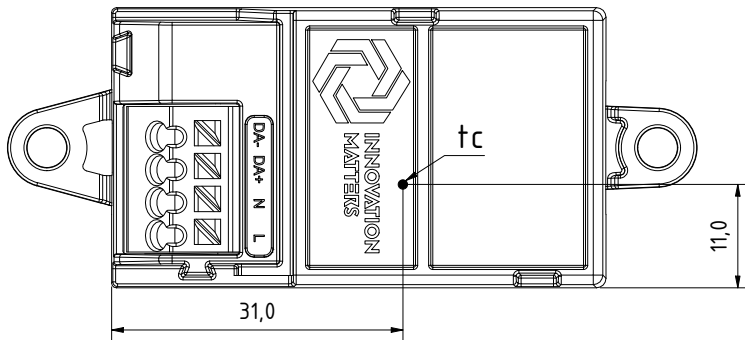

M2D Bridge V1.0

Matter to DALI Bridge - Broadcast



Independent controller

The M2D Bridge V1.0 is only considered as an independent controller if the accessory A-0001 strain relief is used.

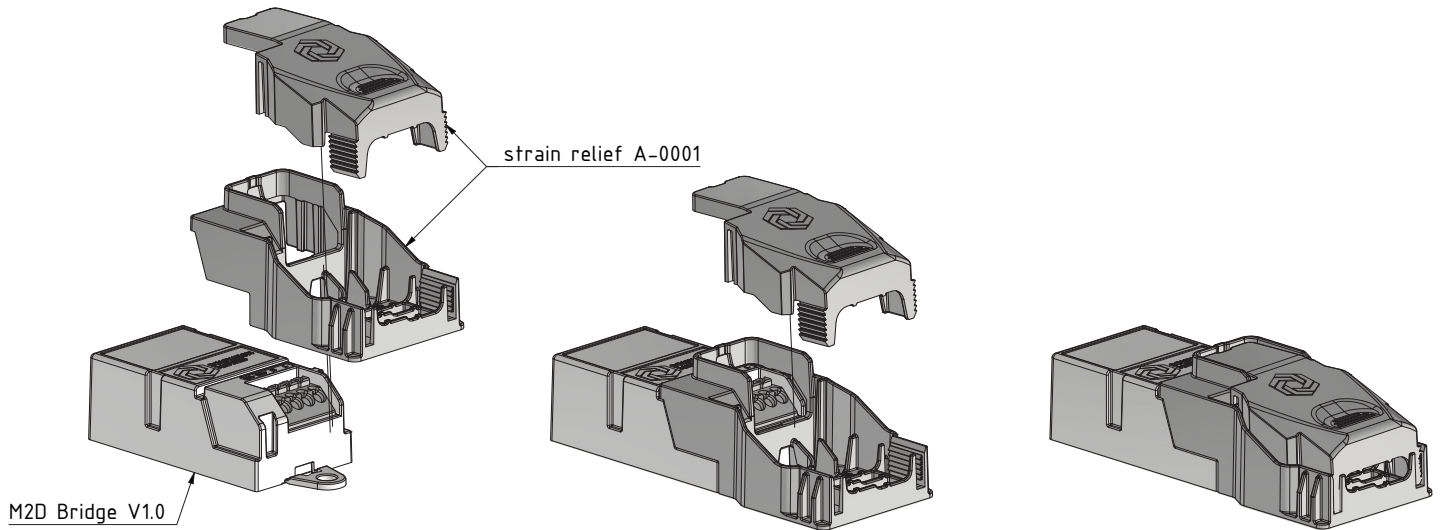

Strain relief A-0001

One cable:

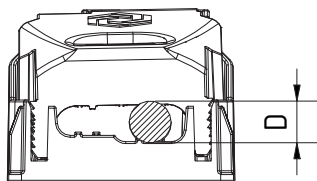

max. cable diameter D: 6.5mm
min. cable diameter D: 4.5mm

Two cables:

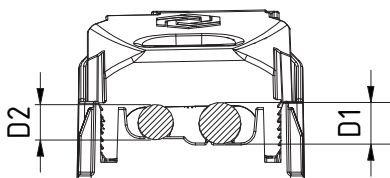

max. cable diameter D1: 6.5mm
min. cable diameter D1: 4.5mm
max. cable diameter D2: D1
min. cable diameter D2: 4.5mm
max. difference D1-D2: 1mm